

PENCERE 
Eurasia **WINDOW**

KAPI 
Eurasia **DOOR**

CAM 
Eurasia **GLASS**

Special Section

ALÜMİNYUM 
Profil, Cephe Sistemleri ve Aksesuarları

2020 Post Show Report



Eurasia Window, Door & Glass

Meeting Point of Window, Door and Glass Industries



12 Halls



110.000 m²



Eurasia's biggest show

Eurasia Window, Door & Glass 2020



Exhibitor Countries

A world map in a dark green color serves as the background. The names of 18 exhibitor countries are listed in white text, grouped into three columns. The first column lists countries from North America and Europe. The second column lists countries from Europe, Africa, and Asia. The third column lists countries from Africa, Europe, and Asia.

U.S.A
Austria
Azerbaijan
Czech Republic
Finland
France
Germany
Holland

India
Israel
Italy
Macedonia
Poland
Romania
Serbia

South Africa
South Korea
Spain
Sweden
Switzerland
Taiwan
Turkey
United Kingdom

Visitor Statistics

45.345

Domestic
Visitors

55.107

Total Visitors

9.762

International
Visitors

Overall Visitor Satisfaction

91%

State that they will visit next year

87%

Highly satisfied with the show



International Visitors

Door & Glass Fairs have hosted **9762** international visitors from **119** different countries this year, with the largest country diversity ever.



Visitor Statistics

In 2020, the show was visited by 55.107 industry professionals in total with 45.345 domestic and 9.762 international visitors.

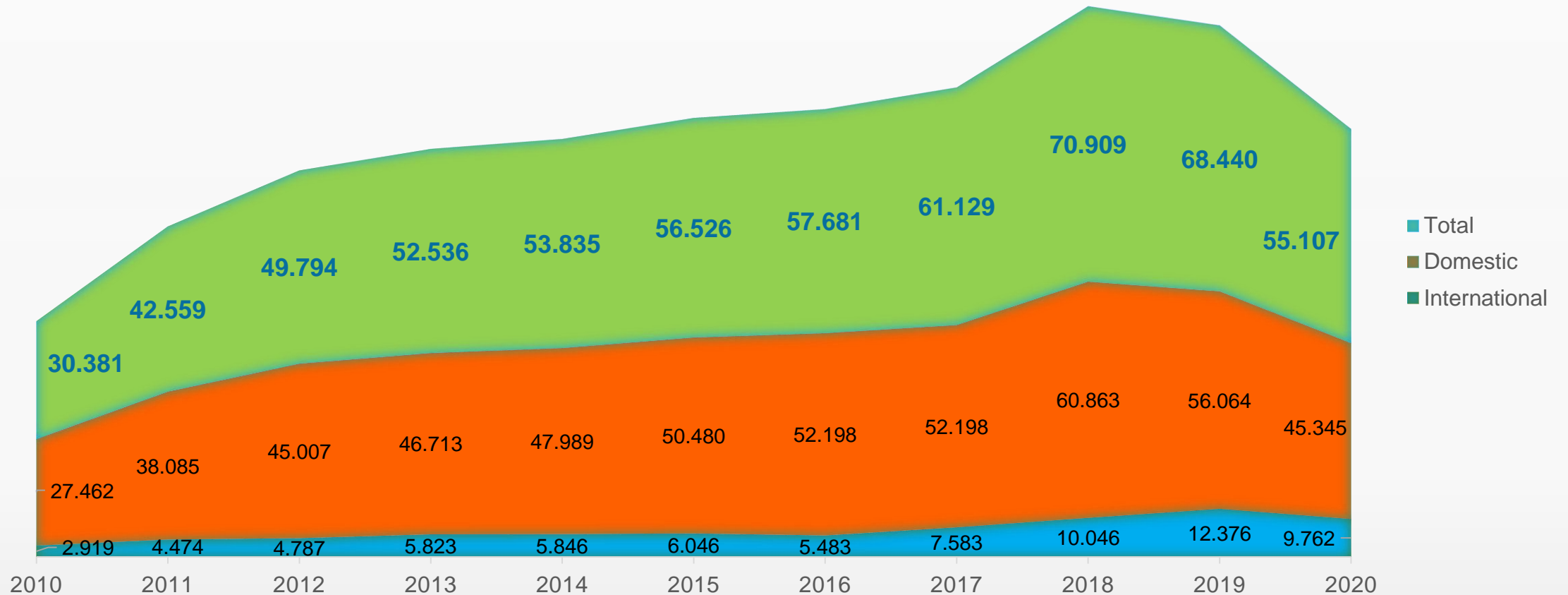

International Visitor Arrivals by World Regions

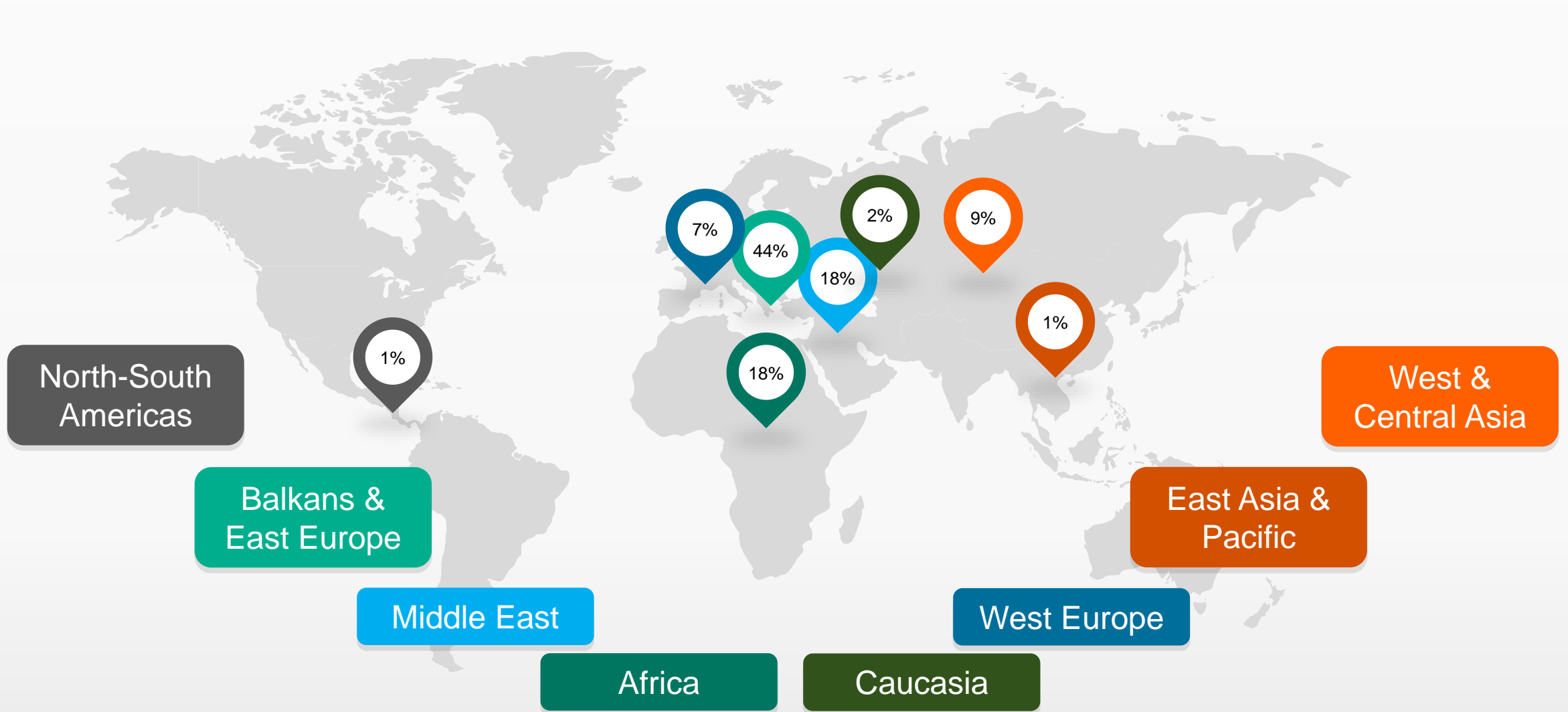

Top 10 Visitor Countries

- MACEDONIA
- KOSOVO
- LIBYA
- ALGERIA
- UKRAIN
- RUSSIA
- SERBIA
- ROMANIA
- BULGARIA
- AZERBAIJAN

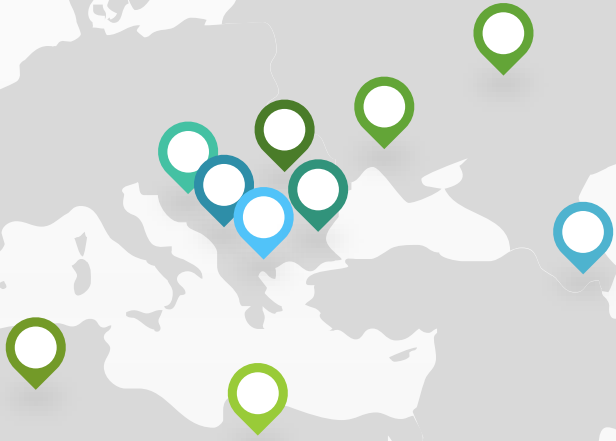

Visitor Breakdown by Industry

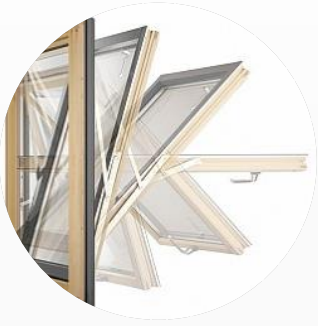

Window & Window Shade
Systems
50%



Window & Door
Accessories
38%

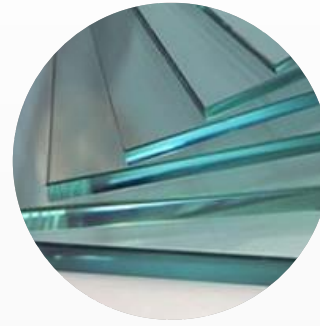

Glass Industry
32%

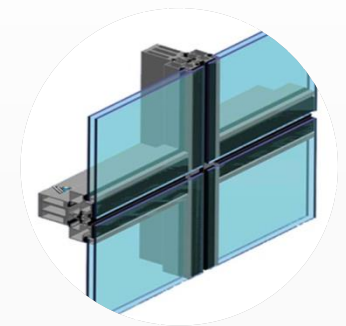

Facade Systems
22%



Door Industry
22%



Plastic Industry
14%



Architecture-Engineering
8%



Others
14%

(Visitors marked multiple fields)

Visitor Breakdown by Industry



Building Materials
7%



Chemical Industry
7%

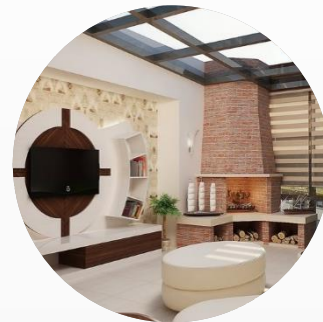

Decoration-
Interior Architecture
6%



Construction Companies
4%



Project Management
4%

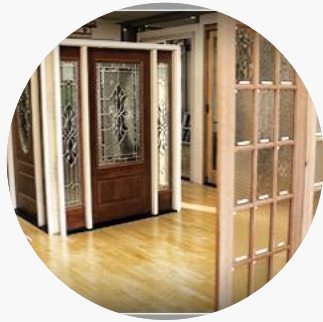

Construction Market
4%

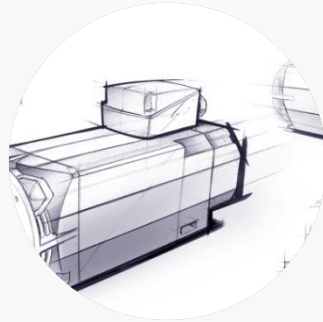

Industrial Design
3%



Hardware-Store
Equipment
2%



Real Estate Corporations
2%

(Visitors marked multiple fields)

Visitor Breakdown by Product of Interest

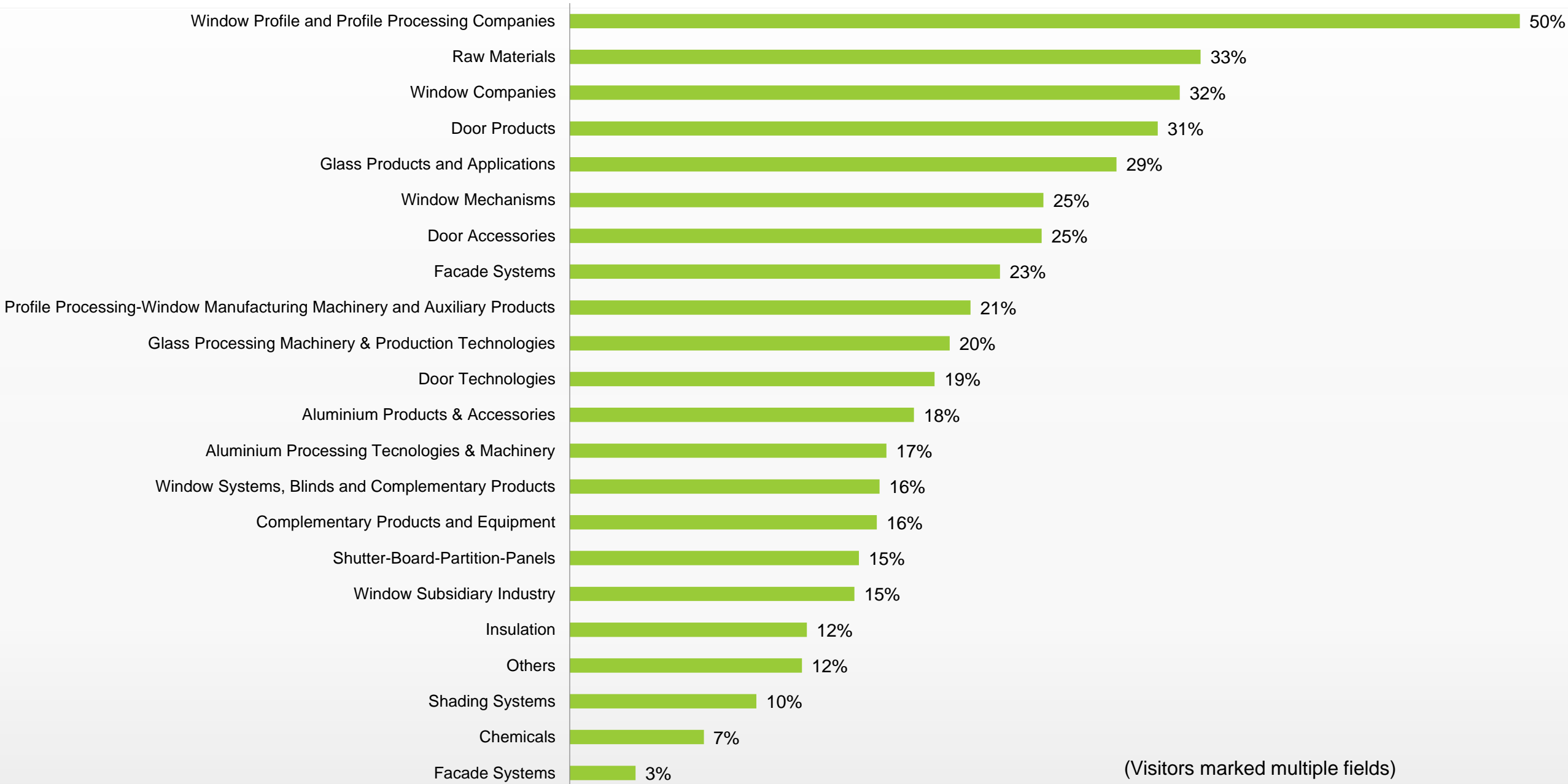

(Visitors marked multiple fields)

Hosted Buyer Program

Eurasia Window, Glass & Door Fairs Hosted buyers from 25 countries and 22 provinces from Turkey .

Countries

Algeria
Azerbaijan
Bosnia and Herzegovina
Bulgaria
Croatia
Egypt
Georgia
Germany
Greece
Kazakhstan
Kosovo
Macedonia
Moldova
Montenegro
Morocco
Poland
Romania
Russia
Serbia
Slovenia
Spain
Tunisia
U.K.
Ukraine
Uzbekistan

Provinces

Adana
Aksaray
Ankara
Antalya
Aydın
Balıkesir
Bilecik
Burdur
Bursa
Denizli
Erzincan
Erzurum
Eskişehir
Gaziantep
Isparta
İzmir
Kayseri
Manisa
Nevşehir
Osmaniye
Sivas
Zonguldak

Visitor Breakdown by Position & Department



Specialists

32%

6%

General Managers

Company Owners / Partners

30%

3%

Assistant General Managers

Managers / Executives

21%

6%

Directors / Coordinators

3%

CEO/CFO/CMO/CTO

Purposes of Visit

Socialising & Networking

While 55% of our visitors are expressing that their purpose of visit is to socialise with their business environment, 24% visited the show to establish new business partnerships.



Trends & Innovations

44% of visitors state that they visit the show to find out about newest trends, technologies & innovations about the industry.



Receiving Orders

77% of our state that have received orders during the Show.



Orders Above \$50.000

29% of our exhibitors state that they have received orders above \$50.000 during the show.

PENCERE 
Eurasia **WINDOW**

SPECIAL SECTIONS

ALÜMİNYUM 
Profil, Cephe Sistemleri ve Aksesuarları

GÖLGELENDİRME 
Koruma & Kapatma Sistemleri

KAPI 
Eurasia **DOOR**

CAM 
Eurasia **GLASS**

Hope to see you at our next event!

3-6 March 2021

www.eurasiawindowfair.com | www.eurasiadoorfair.com | www.eurasiaglassfair.com